

SPECIFICATION FOR SMD LED

Part No: SW2835-0.2W

Description:

2.8*3.5mm SMD LED

Dice Material: InGaN

Confirmed by Customer: _____

Approved by

Checked by

Prepared by



SW2835-0.2W

Sterilize White Series



Introduction

The **Sterilize White series**: kill bacteria and viruses effectively by continuous radiation

Features:

- ◇ More energy efficient than incandescent , halogen and some fluorescent lamps
- ◇ Industry's lowest thermal resistance
- ◇ Long operating life,lumen maintenance of greater than 70% after 50,000 hours
- ◇ Low forward voltage operated
- ◇ Instant light (less than 100ns)
- ◇ Lead Free product, RoHS compliant
- ◇ Natural spectrum:Include Solar Spectrum and Black Body Radiation Spectrum
- ◇ Pb-Free

Application

- ◇ Schools
- ◇ Libraries
- ◇ Exhibitions
- ◇ Offices
- ◇ Reading rooms
- ◇ Laboratories
- ◇ Stadiums
- ◇ Dyeing & Printing
- ◇ Operation lighting
- ◇ Textile workshops
- ◇ Painting workshops
- ◇ Museums
- ◇ Show windows
- ◇ Fresh food stores
- ◇ Markets
- ◇ Photoflood Lamps
- ◇ Art design
- ◇ General Lighting

Package Dimensions:

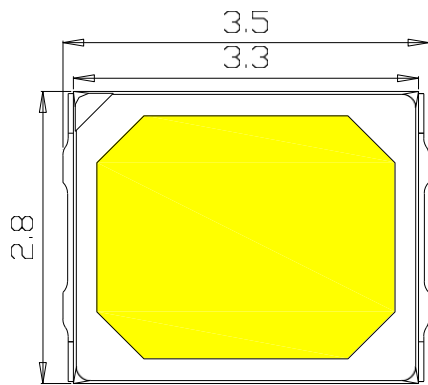

Top View

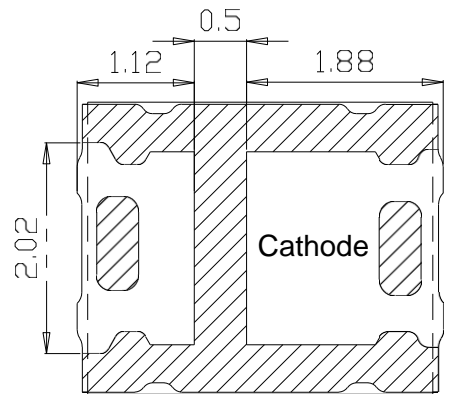

Bottom View

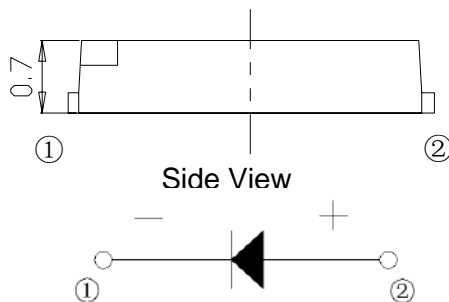

Side View

Recommended Soldering Pad

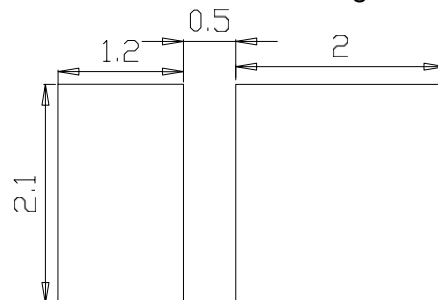

SW2835-0.2W

Absolute Maximum Ratings at Ta=25°C:

Parameter	Part No.	Symbol	Value	Unit	
Power Dissipation	SW2835-0.2W	Pd(max.)	0.98	W	
Peak Forward Current (1/10 Duty Cycle,0.1ms Pulse Width)		If (max.)	150	mA	
Continuous Forward Current		If (Typ.)	30	mA	
LED junction temperature		Tj	125	°C	
Reverse Voltage		Vr	-10	V	
Thermal Resistance, junction to case	SW2835-0.2W	Rθ j-c	70	°C/W	
Soldering Temperature °C		5 seconds, 260°C or lower			
Operating temperature range		Topr	-30°C to + 85°C		
Storage Temperature Range		Tstg	-40°C to + 100°C		

★ Electro-optical characteristics at Ta=25°C

Parameter	Part No.	Symbol	Test Condition	Min.	Typ.	Max.	Unit
Color Rendering	SW2835-0.2W	CRI Ra		90	91		
Color Quality Scale		CQS Qa		90	91		
Fidelity		Rf		85	88		
Gamut		Rg		99	101		
Television Lighting Consistency Index of 99		TLCI		78	80		
Viewing Angle		2θ1/2			111.2		deg
Forward Voltage		V _f	I _f =30mA	5.4	6	6.8	V
Reverse Current		I _r	V _r =-10V			10	uA
Color Temperature 4000K		CCT			4000		K
Luminous flux		φ	I _f =30mA	16.7	18.5		lm

Relative Spectral Power Distribution

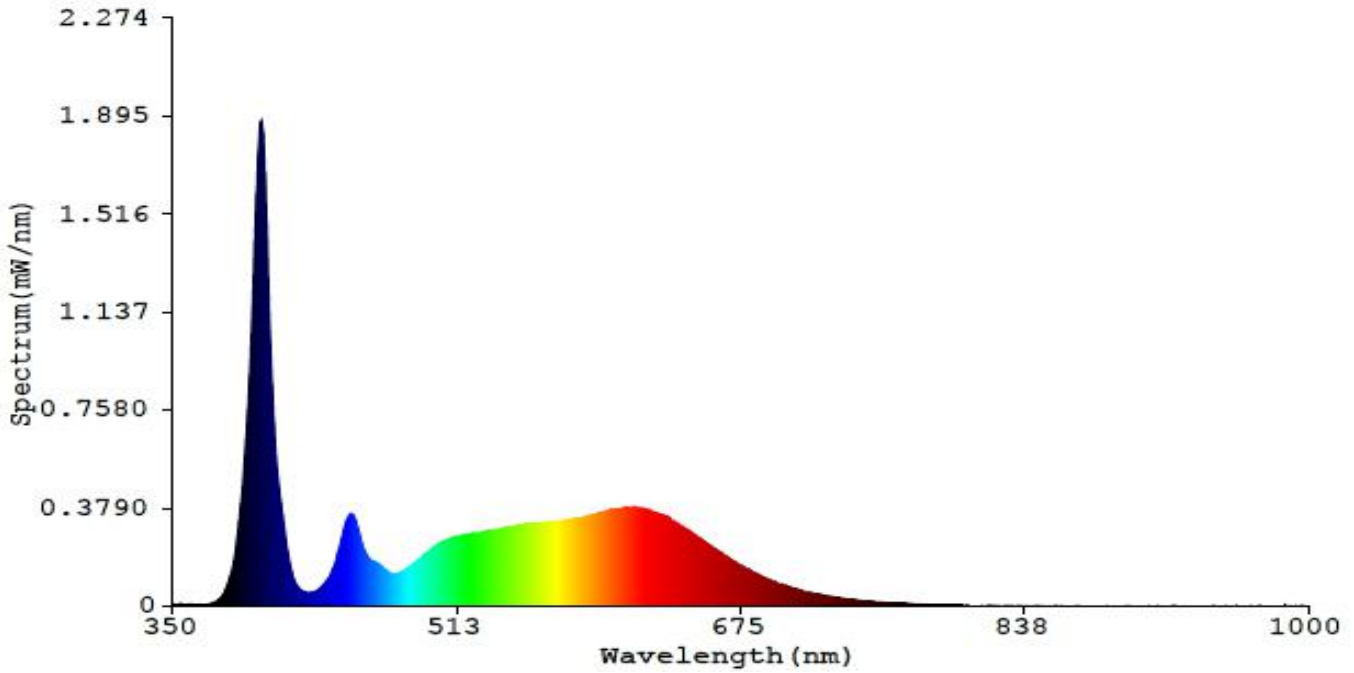

Temperature Characteristics

Relative Luminous(@30mA)VS. Tp Temperature

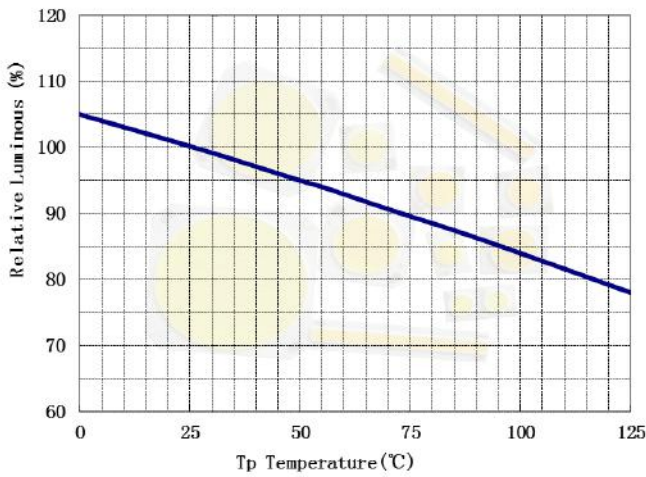

Forward Voltage(@30mA)VS. Tp Temperature

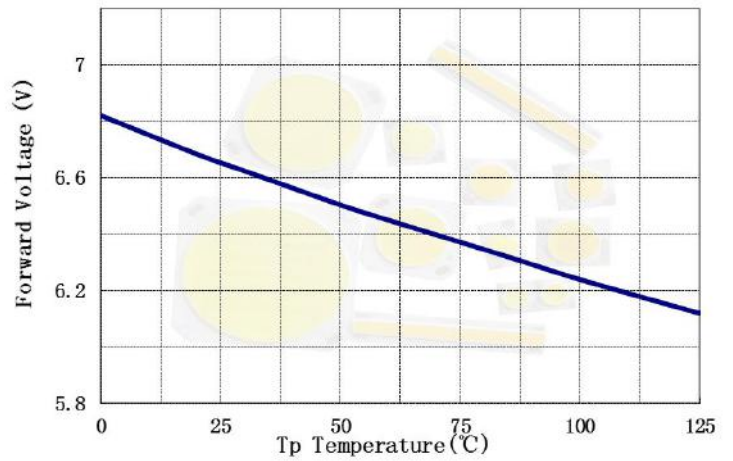

Please ensure the maintenance of heat radiation not to exceed Tj temperature over the rating in operation.

Electrical Characteristics

Relative Radint Flux VS. Forward Current
(Tc=25°C)

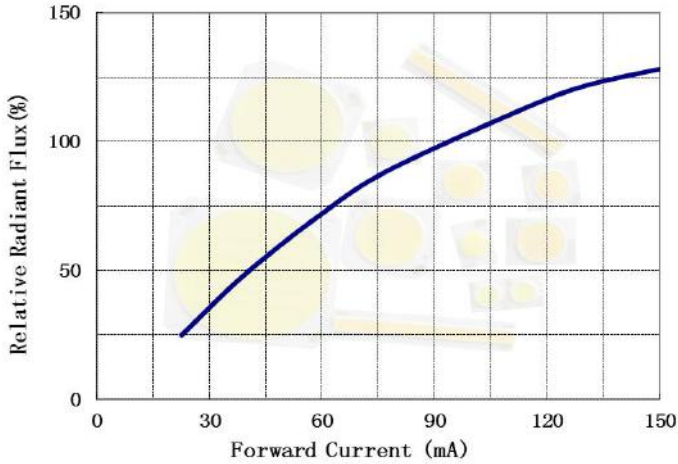

Forward Current VS. Forward Voltage
(Tc=25°C)

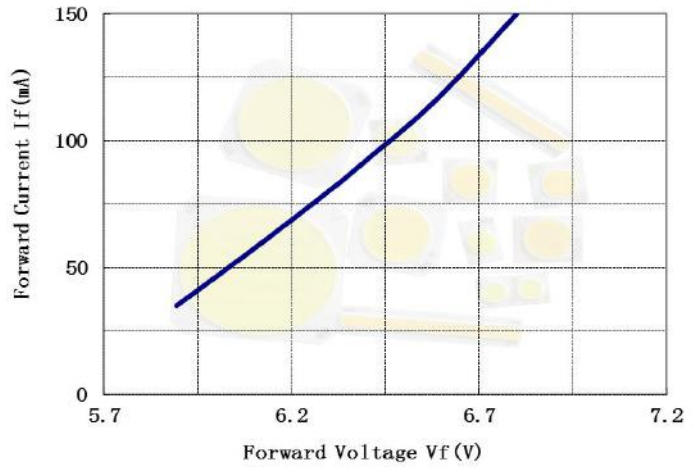

Derating Curves characteristics

Forward Current Derating Curve

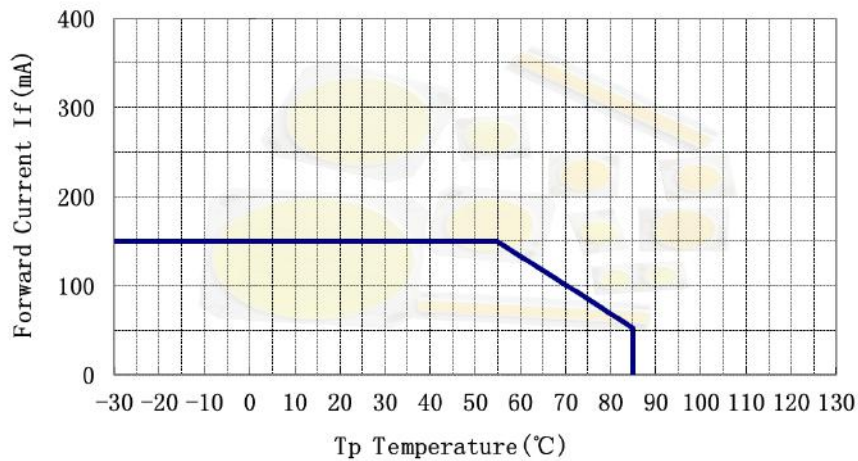

To keep Tp temperature lower than rating enough heat-radiation performance needs to be secured by using an adequate heat sink.

Typical Polar Radiation Pattern

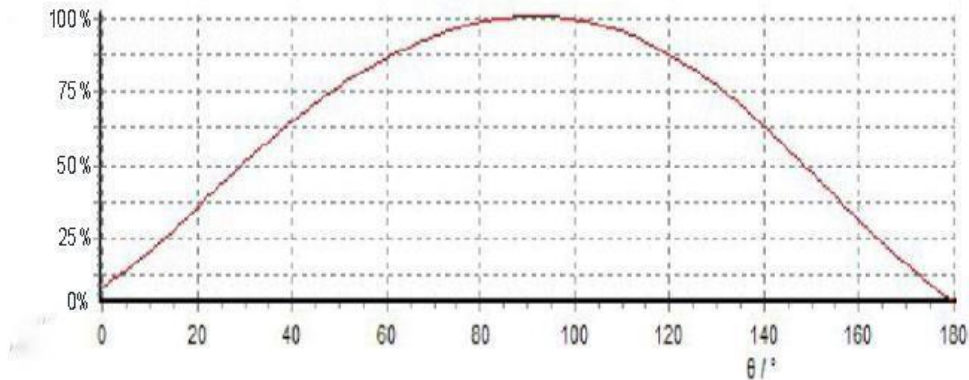

Typical Spatial Radiation Pattern

Chromaticity rank table

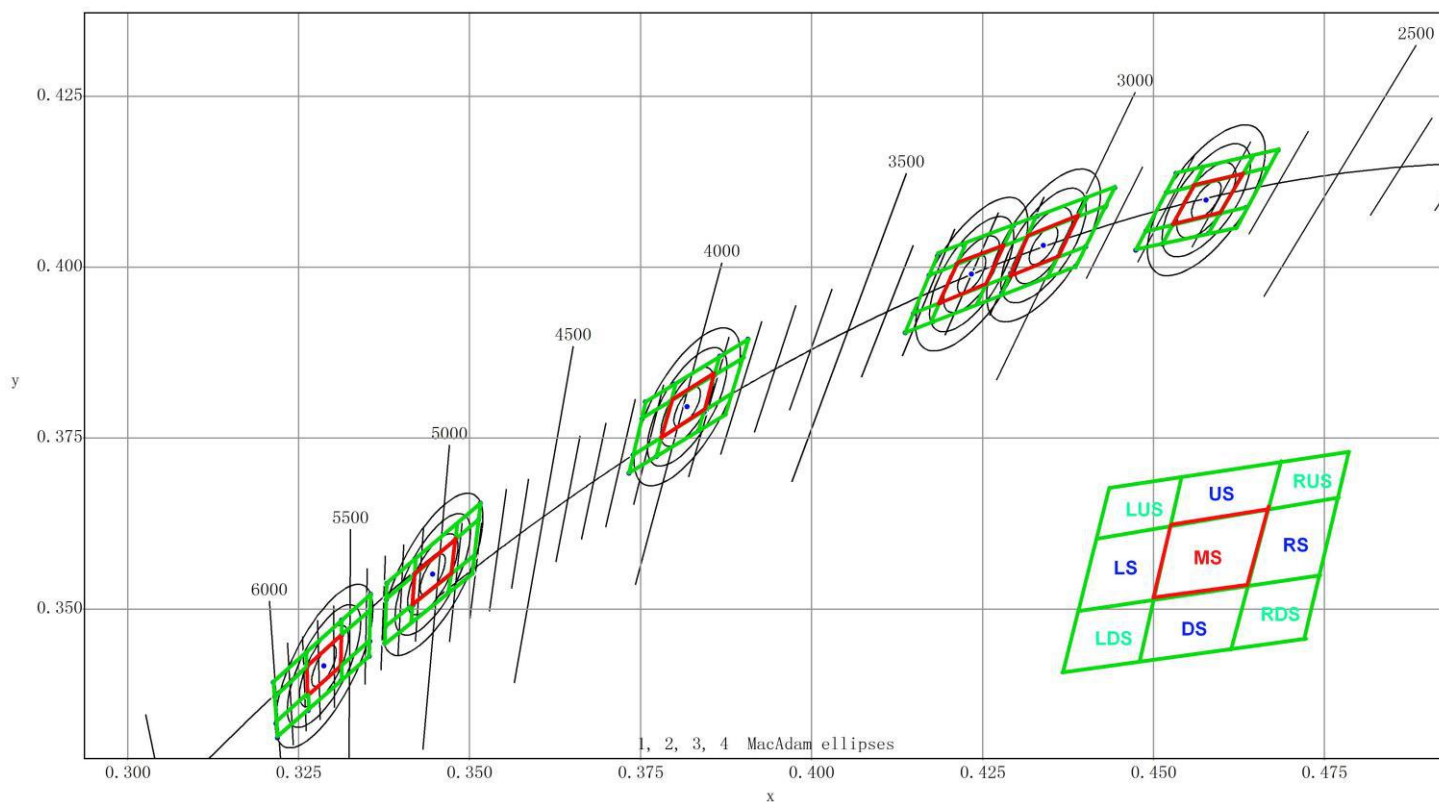

Nominal CCT	Center Point(x,y)		Center Point(u',v')		CCT	Duv	Du'v'
	CIE-X	CIE-Y	u'	v'			
2700K	0.4577	0.4098	0.2615	0.5267	2724	-0.0001	-0.0002
3000K	0.4339	0.4032	0.2490	0.5206	3045	0.0001	0.0001
3200K	0.4234	0.3990	0.2440	0.5173	3200	0.0000	0.0000
4000K	0.3818	0.3796	0.2249	0.5030	3984	0.0009	0.0013
5000K	0.3446	0.3551	0.2097	0.4863	5031	0.0020	0.0025
5600K	0.3287	0.3417	0.2041	0.4773	5666	0.0020	0.0025

CCT	BIN code	CIE-X	CIE-Y	BIN code	CIE-X	CIE-Y	BIN code	CIE-X	CIE-Y	BIN code	CIE-X	CIE-Y	BIN code	CIE-X	CIE-Y
2700K	MS	0.4528	0.4062	LS	0.4528	0.4062	RS	0.4618	0.4083	DS	0.4602	0.4055	US	0.4649	0.414
		0.4558	0.4118		0.4507	0.4057		0.4597	0.4078		0.4492	0.4028		0.4537	0.4113
		0.4629	0.4135		0.4537	0.4113		0.4629	0.4135		0.4507	0.4057		0.4552	0.4141
		0.4597	0.4078		0.4558	0.4118		0.4649	0.414		0.4618	0.4083		0.4665	0.4168
3000K	MS	0.4291	0.3991	LS	0.4317	0.4048	RS	0.4388	0.4073	DS	0.4361	0.4016	US	0.4317	0.4048
		0.4317	0.4048		0.4282	0.4033		0.4429	0.4088		0.4346	0.3986		0.433	0.4075
		0.4388	0.4073		0.4256	0.3975		0.4401	0.403		0.4278	0.3962		0.4402	0.4101
		0.4361	0.4016		0.4291	0.3991		0.4361	0.4016		0.4291	0.3991		0.4388	0.4073
3200K	MS	0.4187	0.3948	LS	0.4187	0.3948	RS	0.4278	0.3985	DS	0.4265	0.3956	US	0.4304	0.4043
		0.4212	0.4005		0.4166	0.3939		0.4257	0.3977		0.4155	0.3911		0.419	0.3996
		0.4282	0.4034		0.419	0.3996		0.4282	0.4034		0.4166	0.3939		0.4201	0.4023
		0.4257	0.3977		0.4212	0.4005		0.4304	0.4043		0.4278	0.3985		0.4317	0.407
4000K	MS	0.378	0.375	LS	0.378	0.375	RS	0.3865	0.3802	DS	0.3857	0.3775	US	0.3881	0.3856
		0.3793	0.3803		0.3758	0.3736		0.384	0.3787		0.3751	0.371		0.3771	0.3788
		0.3857	0.3842		0.3771	0.3788		0.3857	0.3842		0.3758	0.3736		0.3777	0.3815
		0.384	0.3787		0.3793	0.3803		0.3881	0.3856		0.3865	0.3802		0.3888	0.3884
5000K	MS	0.3411	0.3499	LS	0.3411	0.3499	RS	0.3498	0.3571	DS	0.3495	0.3547	US	0.3503	0.3619
		0.3414	0.3546		0.3391	0.3483		0.3476	0.3554		0.339	0.3459		0.3393	0.3529
		0.3482	0.3602		0.3393	0.3529		0.3482	0.3602		0.3391	0.3483		0.3395	0.3552
		0.3476	0.3554		0.3414	0.3546		0.3503	0.3619		0.3498	0.3571		0.3505	0.3644
5600K	MS	0.3253	0.3365	LS	0.3482	0.3602	RS	0.334	0.344	DS	0.3339	0.3418	US	0.3341	0.3488
		0.3252	0.3407		0.3234	0.3348		0.3321	0.3424		0.3235	0.3327		0.3231	0.3388
		0.3321	0.347		0.3231	0.3388		0.3321	0.347		0.3234	0.3348		0.323	0.3409
		0.3321	0.3424		0.3252	0.3407		0.3341	0.3488		0.334	0.344		0.3342	0.351

CCT	BIN code	CIE-X	CIE-Y	BIN code	CIE-X	CIE-Y	BIN code	CIE-X	CIE-Y	BIN code	CIE-X	CIE-Y
2700K	LUS	0.4519	0.4109	RUS	0.4627	0.4134	LDS	0.4528	0.4062	RDS	0.4635	0.4087
		0.4533	0.4137		0.4643	0.4162		0.4513	0.4034		0.462	0.4059
		0.4572	0.4146		0.4682	0.4171		0.4474	0.4025		0.4581	0.405
		0.4558	0.4118		0.4666	0.4143		0.4489	0.4053		0.4597	0.4078
3000K	LUS	0.433	0.4075	RUS	0.4388	0.4073	LDS	0.4291	0.3991	RDS	0.4401	0.403
		0.4295	0.4061		0.4402	0.4101		0.4256	0.3975		0.4386	0.4001
		0.4282	0.4033		0.4443	0.4116		0.4243	0.3947		0.4346	0.3986
		0.4317	0.4048		0.4429	0.4088		0.4278	0.3962		0.4361	0.4016
3200K	LUS	0.4172	0.3988	RUS	0.4282	0.4033	LDS	0.4188	0.3948	RDS	0.4256	0.3975
		0.4184	0.4016		0.4295	0.4061		0.4177	0.392		0.4291	0.3991
		0.4223	0.4032		0.433	0.4075		0.4137	0.3904		0.4278	0.3962
		0.4212	0.4004		0.4317	0.4048		0.4149	0.3932		0.4243	0.3947
4000K	LUS	0.3752	0.3778	RUS	0.3859	0.3843	LDS	0.378	0.375	RDS	0.3882	0.3813
		0.3757	0.3803		0.3866	0.387		0.3773	0.3723		0.3874	0.3785
		0.38	0.3829		0.3907	0.3895		0.3733	0.3699		0.3835	0.3761
		0.3793	0.3803		0.3899	0.3868		0.3739	0.3725		0.3843	0.3788
5000K	LUS	0.3378	0.3514	RUS	0.3477	0.3599	LDS	0.3376	0.3473	RDS	0.3472	0.3549
		0.3379	0.3538		0.348	0.3623		0.3376	0.345		0.3469	0.3524
		0.342	0.3573		0.3516	0.3655		0.3416	0.3482		0.3504	0.3552
		0.3419	0.355		0.3513	0.363		0.3417	0.3506		0.3507	0.3577
5600K	LUS	0.3215	0.3372	RUS	0.3313	0.3462	LDS	0.3217	0.3333	RDS	0.3312	0.3417
		0.3213	0.3393		0.3313	0.3484		0.3219	0.3312		0.3312	0.3395
		0.3261	0.3436		0.3355	0.3522		0.3264	0.3352		0.3353	0.3431
		0.3262	0.3415		0.3355	0.35		0.3263	0.3373		0.3354	0.3453

Luminous rank table

Part No.	CCT	Rank	Luminous Flux(lm)	
	Typ.		Min.	Max.
SW2835-0.2W	4000K	H1	18.5	20.6
		M2	16.7	18.5
		M1	15.0	16.7

Reliability Test

Test Items

Test Items	Test Conditions	Test Hours/Cycles
Room Temperature life test	25° C, IF = Max	1,000 h
High Temperature humidity life test	85° C, 85% RH, DC Derating IF = Max	1,000 h
High Temperature life test	85° C, DC Derating IF = Max	1,000 h
Low Temperature life test	-40° C, DC 150 mA	1,000 h
High Temperature Storage	120° C	1,000 h
Low Temperature Storage	-40° C	1,000 h
Thermal Shock	-45° C/15min → 125° C/15min Temperature changes in 5min.	200 cycles
Temperature Cycle On/Off test	-40 / 85° C, each 20min, 100min transfer Power On/off each 5min, DC 30 mA	100 cycles
Temperature humidity Cycle Storage	-10° C ↔ 25° C, 95%RH ↔ 85° C, 95%RH [24h/1Cycle]	100 cycles
Vibration	20~80Hz (Displacement:0.06inch, Max 20G) 80~2kHz (Max 20G) Min. Frequency ↔ Max. Frequency 4min transfer	4 times
Shock	1500G, 0.5ms, Every 6faces (3axis X 2faces)	5 times
Salt Spray	35° C, salt water 5% 8h spray → 16h leaving alone	2 cycles

Failure Criteria

Item	Symbol	Test Condition [Ta = 25° C]	Limit	
			Min.	Max.
Forward Voltage	Vf	30 mA	L.S.L. × 0.9	U.S.L. × 1.1
Luminous flux	lm	30 mA	L.S.L. × 0.7	U.S.L. × 1.3
* U.S.L. : Upper Standard Level L.S.L. : Lower Standard Level				

Order Code

SW 2835-0.2W-40 M2 F R90 0030- 0201-TE01-XX

x1 x2 x3 x4 x5 x6 x7 x8 x9 x10 x11

Part Number System :

X1: SW: Sterilize White Series

X2: LED Outline: 2835=2.8*3.5mm

X3: LED Power: 0.2W present 0.2 watt

X4: Color temperature: (27、 30、 32、 40、 50、 56...X100)

X5: Luminous Rank Table (H1, M1, M2)

X6: Light efficiency (lm/W) **E**<90lm/w; 90lm/w≤**F**<110lm/w; 110lm/w≤**G**<120lm/w; 120lm/w≤**H**<130lm/w; 130lm/w≤**J**<140lm/w

X7: Color rendering Index(CRI) : 60≤R60<65 ; 65≤R65<70 ; 70≤R70<75; 75≤R75<80 ; 80≤R80<85 ; 85≤R85<90 ; 90≤R90<95 ; 95≤R95<97 ; 97≤R98≤98 ;

X8: Default Forward Current(I_f). 0030=30mA

X9: Serials and Parallels: 0201=2 Serial 1 Parallels

X10: Substrate Code, Factory used only

X11: Chromaticity bin code

NOTICE:

- All dimensions are in millimeter.
- Tolerance is ±0.1mm unless otherwise noted.
- It is strongly recommended that the temperature of lead be not higher than 70°C.
- This information in this document is subject to change in order to improve reliability, design or function without prior notice and does not represent a commitment on the part of this company.

Avoids preserving in the high temperature, the high-moisture, as well as in the acidic environment .

Moisture Resistant Packing Materials

Label Explanation

Part No.:XXXX-XX

CODE:XXXXXXXX-XXXX-XXXX-XXXX

VF:XX-XXV IF:XXmA

Ra:>XX CCT:XXXXK

B/N:XX Φ:XX-XXlm

QTY:XXPCS

LOT:XXXXXX-XX



Reel Dimensions

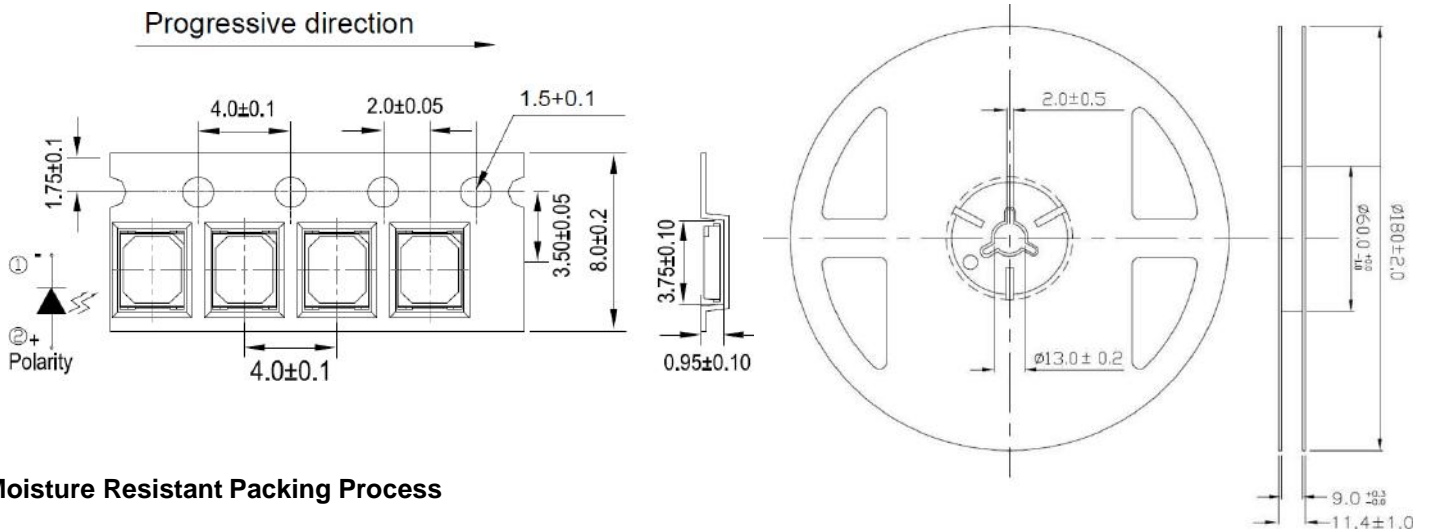

Moisture Resistant Packing Process

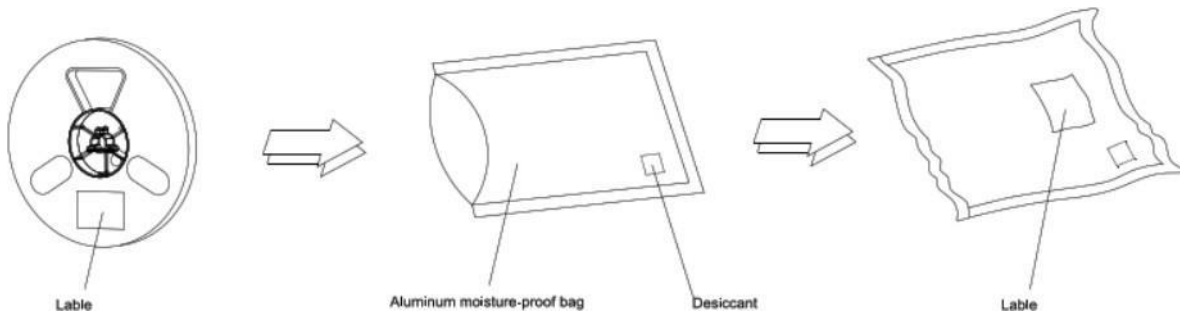

Note:

Tolerances unless mentioned ±0.1mm. Unit = mm

Soldering Condition

Pb-free solder temperature profile

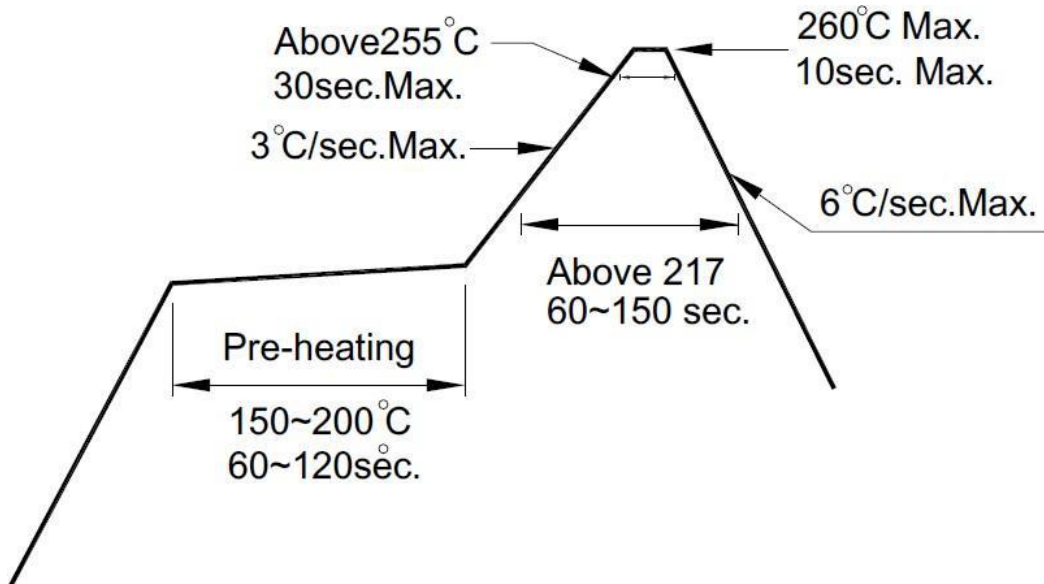
**Cautions**

1. Reflow soldering should not be done more than two times.
2. When soldering, do not put stress on the LEDs during heating.
3. After soldering, do not warp the circuit board.